

**DESCRIPTION :**

The WM - VI is High Capacity Tank / Hopper / Rail Weigh Module for 90210 / 90310 hermetically sealed canister load cells.

- Capacities from 5Tf. to 200Tf.
- Stainless Steel or Mild Steel zinc plated
- Self-checking - no check rods needed
- Over turn restraint option

DIMENSIONS :

CAPACITY (Tf.)	L/C USED	MODEL NO.	A	B	C Max.	D	E	F	G	H Dia.
5-30	90210/90310	WMVI-A	254.0	152.0	156.0	19.0	114.0	76.0	25.0	17.5
45,50,60	90210/90310	WMVI-B	279.0	203.0	229.0	25.0	152.0	89.0	38.0	21.0
100-200	90210/90310	WMVI-C	330.0	254.0	310.0	25.0	203.0	114.0	51.0	28.0

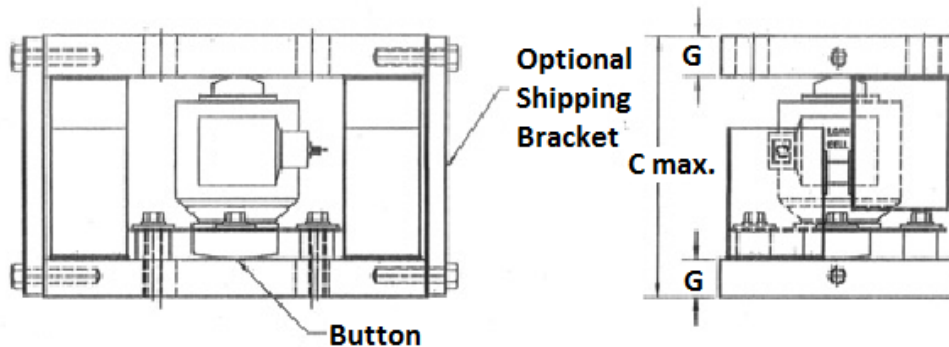
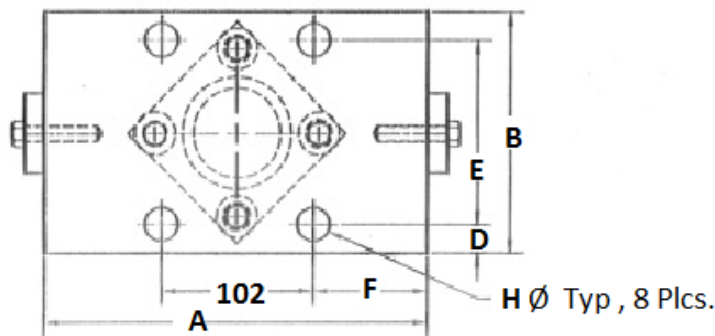
**APPLICATIONS :**

- Truck scales
- Heavy-capacity horizontal tanks
- Railroad track scales

Specification are subject to change.

All dimensions are in mm.



Made in INDIA by:

ADI ARTECH
TRANSDUCERS PVT. LTD.

A Joint venture with
 ARTECH INDUSTRIES INC., U.S.A

917/1, G.I.D.C. Estate, Makarpura, Vadodara - 390 010, Gujarat, INDIA

Mobile : +91-9374068998, 9879444551, 9054467370

Email : sales@adiartech.com, adiartech@adiartech.com

Website : www.adiartech.com