

DESCRIPTION

WM-V is weighing assembly for load cell model 70310. It is designed to simplify the weigh bridge installations. It is supplied in mild steel construction with Zink plating for corrosion resistance.

Shackle type link assembly minimizes non axial load to the load cell and allows reliable and accurate Weigh measurements in vibrating deck due to truck movements.

FEATURES

Easy to install

Eliminates the need of tie rods and other accessories

APPLICATIONS

Truck Scales

Tank, Hopper, Bin Weighing

Railroad Track Scales

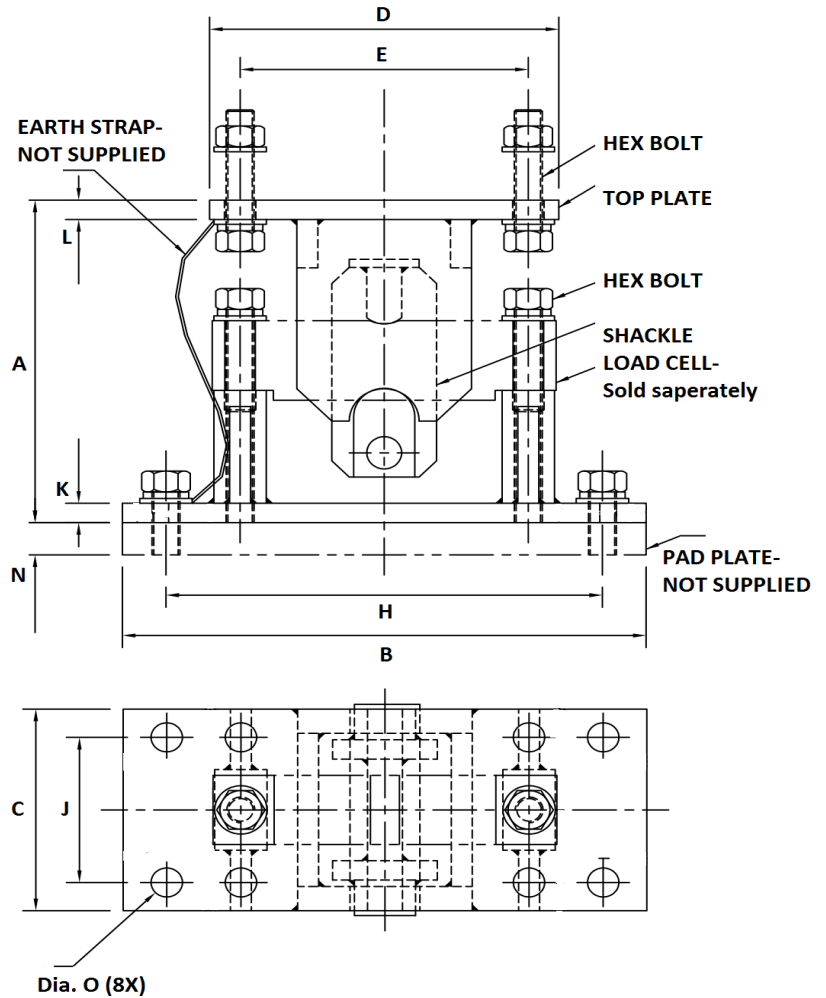
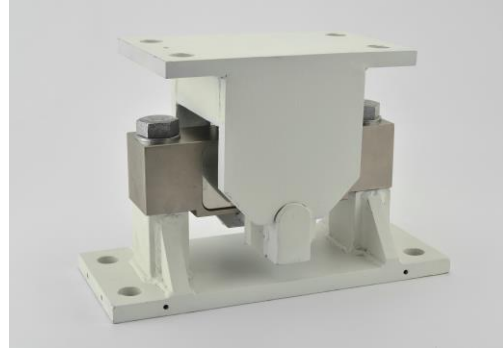

Capacity-Tf.	A	B	C	D	E	H	J	K	L	N*	O
5, 10	200	300	125	200	165	250	90	12	12	20	18
15, 20, 23, 30	230	350	150	250	200	300	90	15	15	25	22

*Not supplied

Specifications are subject to change.

All dimensions are in mm. without notice.



Made in INDIA by:

ADI ARTECH
TRANSDUCERS PVT. LTD.

A Joint venture with
ARTECH INDUSTRIES INC., U.S.A

917/1, G.I.D.C. Estate, Makarpura, Vadodara - 390 010, Gujarat, INDIA

Mobile : +91-9374068998, 9879444551, 9054467370

Email : sales@adiartech.com, adiartech@adiartech.com

Website : www.adiartech.com